

Kränzle

Operating manual
high-pressure cleaner

Kränzle

1122TST

220 V~ / 60 Hz
www.kraenzle.co



Kränzle 1122 TST

P: 120 Bar / 12 MPa
P max: 140 Bar / 14 MPa
Q: 7.5 l/min
T max: 60° C **02-13**

220 Volt	60 Hz	7.5 A
1700 rpm	I. Cl.: F	IP 55
P1: 1.7 kW	P2: 1.2 kW	

Serial-No.: **Kränzle**
BY-01459915 Made in Germany

Reprint only allowed with the authorisation of Kränzle

Effective 03.09.2012



Subject to technical modifications. Order no. 30.792.01USA



Read and conform safety instructions before use!
Keep instructions in a safe place for later use and pass them on to any future user.

- Korea -



2 Description of high-pressure cleaner

Kränzle 1122 TS T

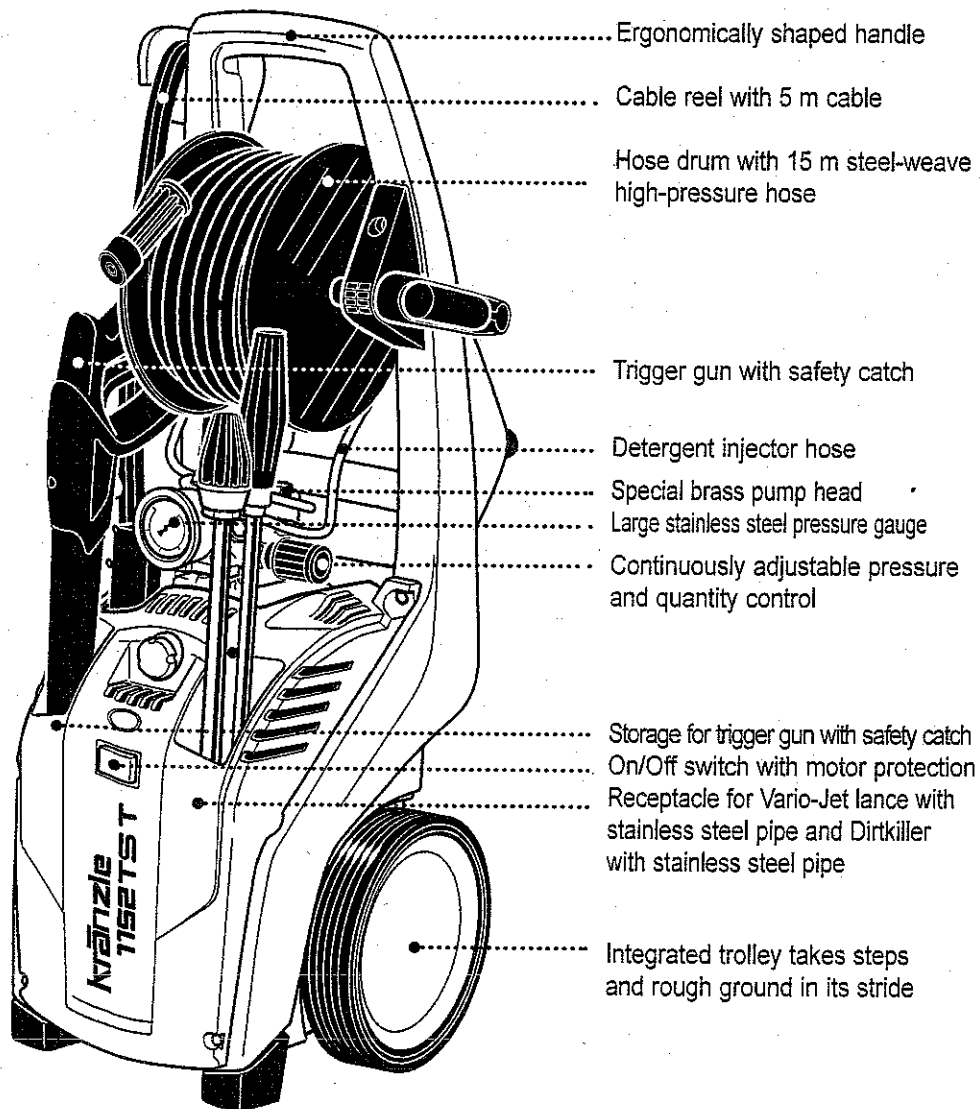

Ergonomically shaped handle

Cable reel with 5 m cable

Hose drum with 15 m steel-weave high-pressure hose

Trigger gun with safety catch

Detergent injector hose

Special brass pump head

Large stainless steel pressure gauge

Continuously adjustable pressure and quantity control

Storage for trigger gun with safety catch

On/Off switch with motor protection

Receptacle for Vario-Jet lance with stainless steel pipe and Dirtkiller with stainless steel pipe

Integrated trolley takes steps and rough ground in its stride

Contents

Description	2
Contents	3
Technical data	4
Overview "This is what you have purchased"	5
General rules - accident prevention	6
Safety precautions - accident prevention	7
Please note - important	10
Kränzle- technology	12
Putting into operation	14
Suction of detergents	18
To shut down the pump	19
Small repairs – do it yourself!	20
EC declaration of conformity	24
Guarantee	25
Versatile due to Kränzle accessories	26
Inspections – inspection reports	44

4 Technical data

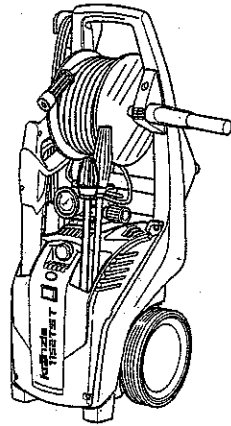

Kränzle 1122 TS T

Operating pressure, steplessly adjustable	120 bar / 12 MPa
Nozzle size	03
Perm. overpressure	140 bar / 14 MPa
Water output	at 1.700 U/min 7,5 l/min
Water inlet pressure	10 bar / 1,0 MPa
Water inlet temperature	max. 60 °C
Hose drum	yes
Steel braided high-pressure hose	15 m, NW 6
Detergent suction	yes
Total stop	yes
Connected load	220 V~, 7,5 A, 60 Hz
Power input	P 1 - 1,7 kW
Power output	P 2 - 1,2 kW
Weight	31,5 kg
Dim. incl. pulling handle in mm	360 x 365 x 870
Sound level acc. to DIN 45 635	88 dB (A)
Sound level with Dirtkiller	90 dB (A)
Acoustic power L _{WA}	93 dB (A)
Recoil at lance	ca. 27 N
Vibration at lance	1,9 m/s ²

Zulässige Abweichung der Zahlenwerte ± 5 % nach VDMA Einheitsblatt 24411

This is what you have purchased

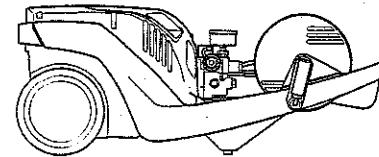

1. Kränzle high-pressure cleaner 1122 TS T with 15 m steel-weave high-pressure hose and hose drum

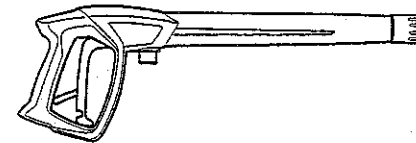

2. Trigger gun with insulated handle and screw connection



3. Dirtkiller lance with stainless steel pipe (except order no. 41.217)

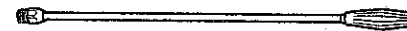

4. Vario-Jet lance with stainless steel pipe



5. Handle with fixing screw for hose drum



6. Attachment hook for cable with 2 fixing screws

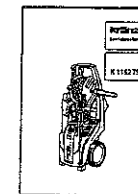

7. Operating manual

6 General rules

■ Range of application

Use machines for cleaning tasks with high-pressure water jet and detergents or with high-pressure water jet without detergents only.

■ Inspections

The machine must be inspected according to the "Guidelines for Liquid Spray Devices" at least once every 12 months by a qualified person, to ensure that continued safe operation is guaranteed. The results of the inspection are to be recorded in writing. This may be done in any form. For inspection reports see pages 58-59.



High-pressure cleaners used for commercial purposes have to be checked by a qualified person at least every 12 months!

■ Accident prevention

The machine is designed for accidents to be impossible if used correctly. The operator is to be notified of the risk of injury from hot machine parts and the high pressure water jet. The "Guidelines for Liquid Spray Devices" must be complied with (see pages 36-38).

■ Oil change:

The first oil change should be carried out after approximately **50 operating hours**. After that no further oil change will be necessary to perform an oil change for the life cycle of the high-pressure cleaner. If it becomes necessary during repairs, or because the oil has a greyish colour then the oil draining screw should be opened and the oil emptied into a container. The oil is to be caught in the reservoir and disposed of in an approved manner. **New oil: 0.25 l - Motor oil: W 15/40.**



Oil leakage: If oil leaks contact your nearest after-sales service (dealer) at once. (Environmental damage, damage to the transmission)



In case of increased humidity or fluctuations in temperature development of condensed water is possible; if the oil turns grey, it must be changed.

Safety precautions

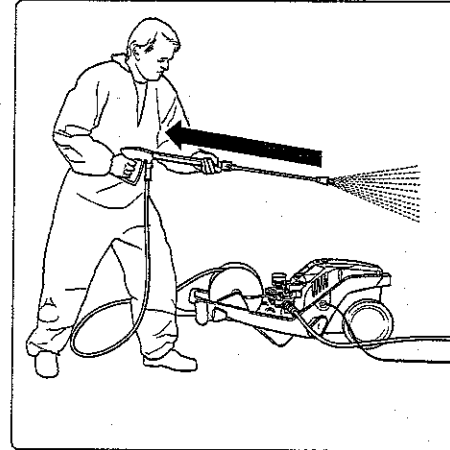

Bear in mind that during cleaning tasks with a high-pressure water jet a significant recoil at the lance arises. Please stand firmly.

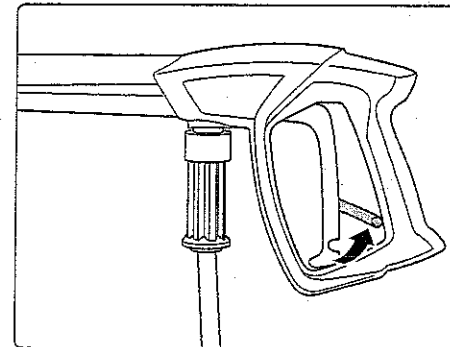

Apply safety catch on the trigger gun after each use, in order to prevent unintentional spraying!

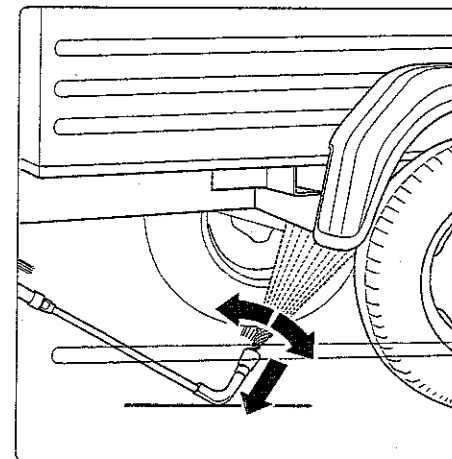

Always aim the underbody lance! Bear in mind when using a curved or angled spraying lance that there is a significant amount of torque in the recoil (the underbody lance is available as optional accessory)

8 Safety precautions – This is prohibited!

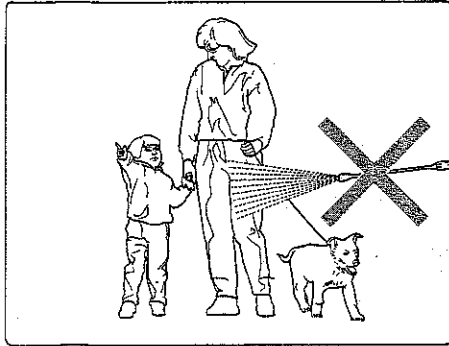

Never direct the water jet at people or animals!

Never direct the high-pressure jet at yourself or other persons, not even to clean clothing or shoes.

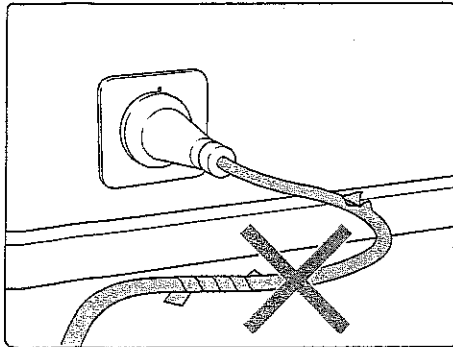

Only use power cables which are in perfect working order!

Do not damage the power cable or repair it incorrectly!

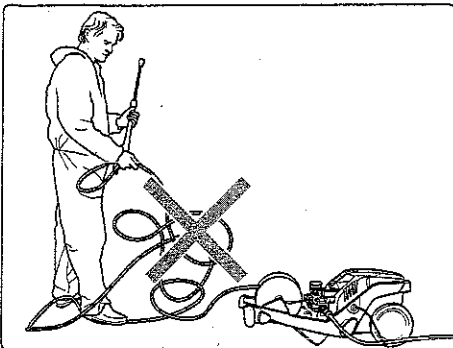

Never pull the high pressure hose if it has formed kinks or "nooses"!

Never pull the hose over sharp edges!

9

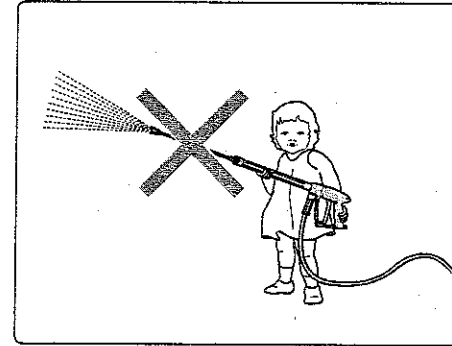

Never allow children or untrained persons to use the high pressure cleaner!

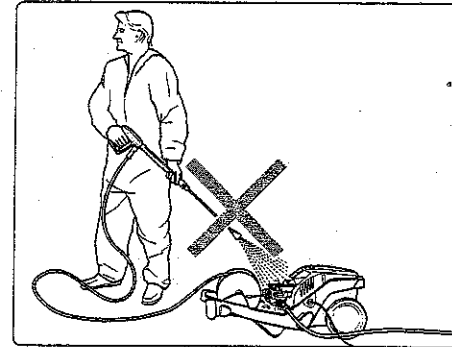

Never direct the water jet at the machine itself!

The machine may not be placed within reach of the water jet spray mist!

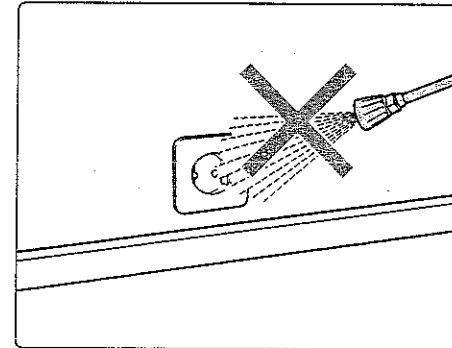

Never direct the water jet at power sockets or any other electrical installations!

10 Please note - important:

■ Lack of water

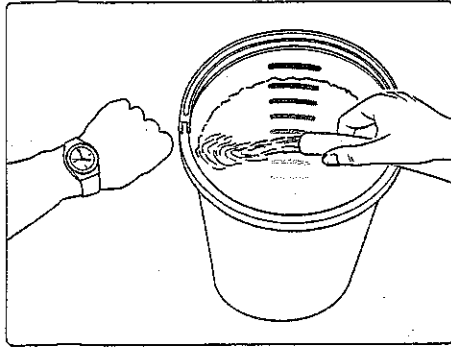

Lack of water occurs more often than you probably believe. The more powerful a high-cleaner is the greater is the danger that a lack of water occurs. If there is only an insufficient amount of water available, cavitation (water-gas mixture) arises inside the pump, which is normally noticed too late or even not at all. **The pump will be destroyed!** Please check the available quantity of water by filling a bucket with litre scale for one minute.

A minimum water quantity of 7,5 litres per minute must be available to guarantee a trouble-free operation of the Kränzle 1122 TS T.



If the metered quantity of water is too small, you have to use a different water connection, guaranteeing the necessary output.



Lack of water leads to an accelerated wear of the joints (guarantee void).

■ Water supply



Please pay attention to the regulations of your waterworks company! In accordance with DIN EN 61770, the machine may not be directly connected to the public drinking water supply lines. A brief connection however is permissible according to DVGW (German Association for Gas and Water Affairs) if a non-return valve with tube ventilator (Kränzle order no. 41.016 4) is built into the water supply. **Once the water has passed through the non-return valve it is no longer considered as drinking water.**

Also indirect connection to the public drinking water supply lines is permissible by way of free emission in accordance with EN 61 770; e.g. by using a reservoir with a float valve.

Direct connection to a non-drinking water supply line is permissible.

■ Insufficient quantity of electricity

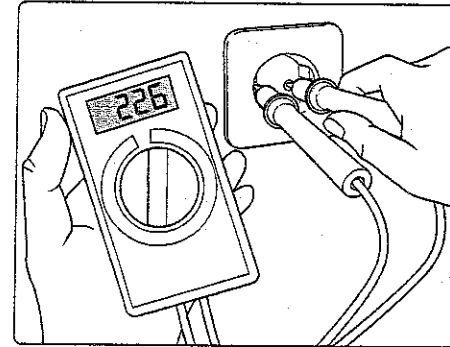

If there are too many collectors in your proximity connected to the network at the same time, the available voltage and the current intensity may decline. Consequently the motor of the high-pressure cleaner does not start or even blows.

The power supply may also be insufficient if the power cable is too long or too thin.

If extension cables are too long, this may lead to a voltage drop causing malfunctions or start-up difficulties.

Kränzle 1122 TST:
220 V ~, 7,5 A, 60 Hz



Check the line fusing and have the voltage and the available current intensity checked by an expert in case of uncertainty.

■ Electrical connection

The machine is supplied with a 5 meter electrical power cable with plug. The mains plug must be fitted to a standard grounded socket with a 30mA residual current operated device. The socket must be protected **with a 16A delay action** fuse on the mains side.

When using an extension cable, this must have an earthed lead which is properly connected to the socket. The conductors in the extension cable must have a minimum cross section of 1.5 mm².

Plug connections must be of a spray-proof design, and may not be located on a wet floor. With extension cables of **more than 10 m** the minimum cross section must be 2.5 mm! When using a cable drum, always keep the cable wound as far as possible.

■ Water and cleaning system

Water can be connected at mains pressure (1-8 bar pre-pressure) to the high-pressure pump. The water is then forced under pressure by the high pressure pump to the lance. The high pressure jet is formed by the nozzle at the end of the lance.



Environmental, refuse disposal and water protection regulations must be observed!

■ Lance with trigger gun with safety catch

The machine can only be operated when the trigger of the trigger gun with safety catch is pulled. When the trigger is pulled, the trigger gun opens. The liquid is then pumped to the nozzle. The spray pressure increases and quickly reaches the selected operating pressure. When the trigger is released, the trigger gun closes and any further spraying of liquid from the lance is stopped. The pressure gauge must show 0 bar. When the trigger gun with safety catch is closed the increase in pressure causes the pressure control valve/safety valve to open. The motor is switched off by the pressure switch. When the trigger gun is opened, the pressure control valve/safety valve closes, the motor is started and the pump resumes pressure spraying from the lance with the selected operating pressure.



The trigger gun with safety catch is a safety device. Repairs should only be performed by qualified persons. Should replacement parts be required, use only components authorized by the manufacturer.

■ Pressure control valve - safety valve

The pressure control valve - safety valve protects the machine from a build up of excess pressure, and is designed not to permit an excess pressure to be selected for operation. The limit nut on the handle is sealed with a spray coating. The operating pressure and spray rate can be steplessly adjusted by turning the handle.



Replacements, repairs, new adjustments and sealing should only be performed by qualified persons.

■ Total stop system

Kränzle 1152 TS T high-pressure cleaners are equipped with a total stop system. If the main switch is switched on the motor is started by a pressure switch, as soon as the trigger gun with safety catch is operated. If the trigger gun is released the motor is switched off at once.

■ Motor protection switch

The motor is protected from overload by a motor protection switch, which cuts out the motor in the event of overload. However should the switch trip frequently, the cause of the malfunction should be located and rectified (see page 40).



Replacements and inspection work should only be performed by qualified persons when the machine is disconnected from the power supply, i.e. with plug pulled out from the electrical socket.

■ High pressure hose and spray device

The high pressure hose and spraying device supplied with the machine are made of high grade material, they are also optimized for the machine and marked as required by the appropriate regulations. (max. hose length 20 m)

If replacement parts are required, only such parts that are authorized by the manufacturer may be used. The warranty is automatically void if spare parts of third-party providers are used! The high pressure hose and spray device must be connected in a pressure-tight manner (without leakage).



The high pressure hose may not be driven over, pulled excessively, or twisted. The hose may under no circumstances be pulled over sharp edges. Defective high-pressure hoses must not be repaired (acc. to DIN 20022) but have to be replaced by new hoses approved by the manufacturer.

■ Explanatory symbols affixed to the high-pressure cleaner



Operate high-pressure cleaner in horizontal position only. Never direct the high-pressure jet at people or animals. Never direct the water jet at power sockets or any other electrical installations!



The high-pressure cleaner may only be operated in horizontal position!

14 Putting into operation

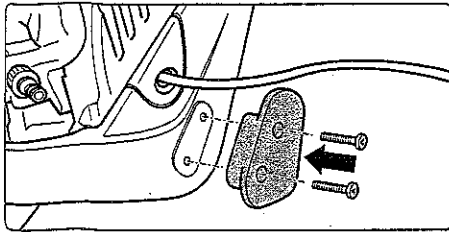

1. Screw bottom attachment hook for cable to the respective position on the frame.

■ Setting up – Location



Neither set up or operate the machine in rooms where there is a risk of fire or explosion nor put it into puddles. Do not use the machine under water.

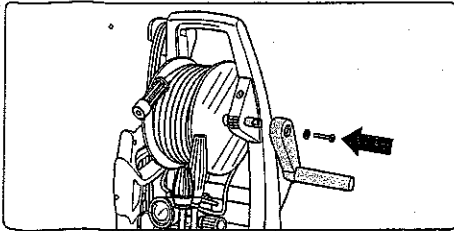

2. K 1122 TS T: Put up machine. Release fixing screw from hexagonal base of hose drum, put tiltable handle onto the hexagonal base and fix with screw.

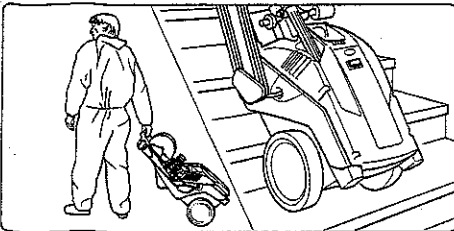

3. Move high-pressure cleaner to the job site. The Kränzle 1122 TS T is a movable machine with sturdy trolleys ideally suited for difficult terrain and stairs.

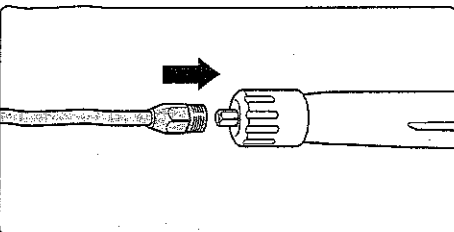

4. Push Vario-Jet lance or Dirtkiller lance on to trigger gun with safety catch.

Putting into operation

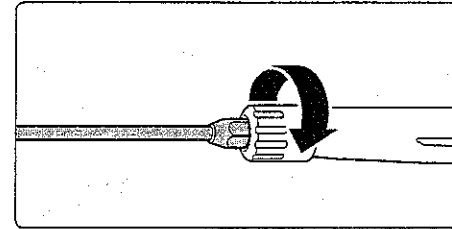

5. Screw together lance and trigger gun pressure-tightly.

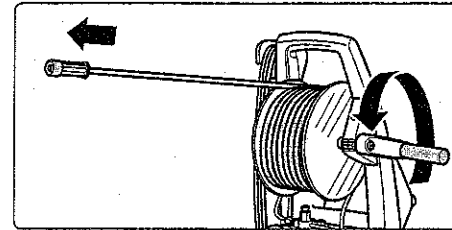

6. Unwind high-pressure hose straight and without nooses. (When using hose extensions take care that the max. length of 20 m is not exceeded!)

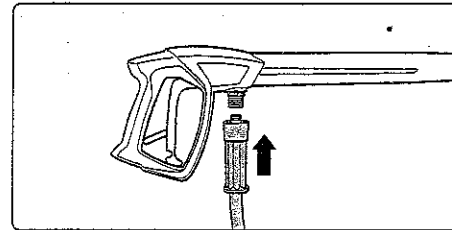

7. Push on high-pressure hose to trigger gun with safety catch.

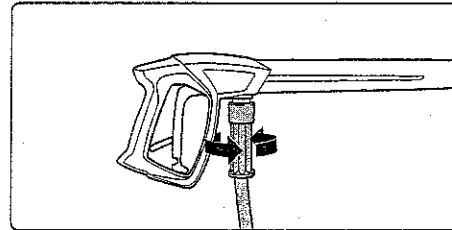

8. Tightly screw together high-pressure hose and trigger gun with safety catch.

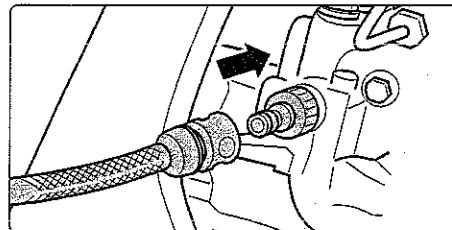

9. Connect water hose to water inlet.

The cleaner may be connected to a water mains (1-10 bar pre-pressure) with either cold or hot water (up to 60°C).

■ Be careful when using hot water!



When running your high pressure cleaner with hot water of 60° C raised temperatures occur. Do not touch the metal parts of the cleaner without safety gloves!

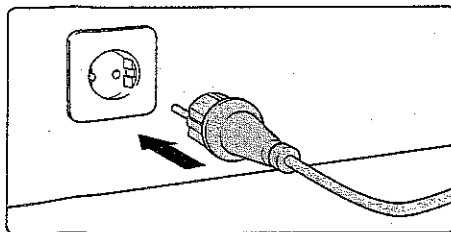

10. Connect to circuit.
Kränzle 1122 TS T:
220 V ~, 7.5 A, 60 Hz
The socket must be protected with a 16A delay action fuse on the mains side.

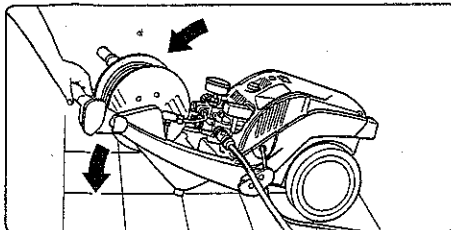

11. Put HP cleaner into horizontal position. The machine must be operated in horizontal position!

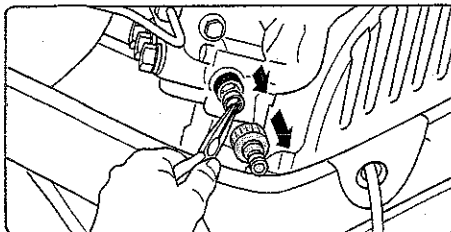

12. Check water inlet filter for cleanliness prior to putting the machine into operation!
Manually unscrew hose attachment. Take out the serial water inlet filter using needle nose pliers and clean if filter is soiled.

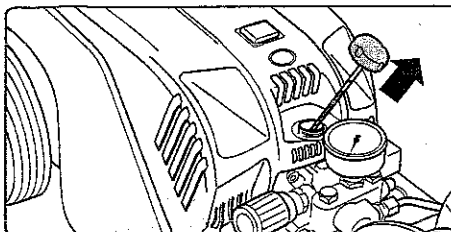

13. Prior to putting HP cleaner into operation always check oil level at oil-level glass.
(Make sure that cleaner is in horizontal position!) The oil level must reach the top edge of the "OK" marking.



14. Switch on HP cleaner with opened trigger gun (trigger pulled). Bleeding of the machine: Pull and release trigger of trigger gun with safety catch several times.
Start cleaning task.

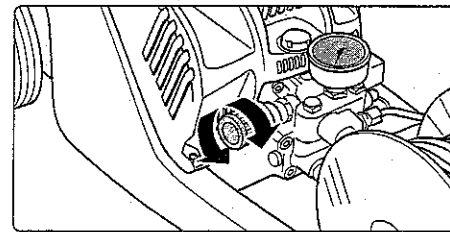

15. Steplessly adjust operating pressure with handwheel. The maximum pressure is adjusted ex work.
Kränzle 1122 TS T: max. 120 bar

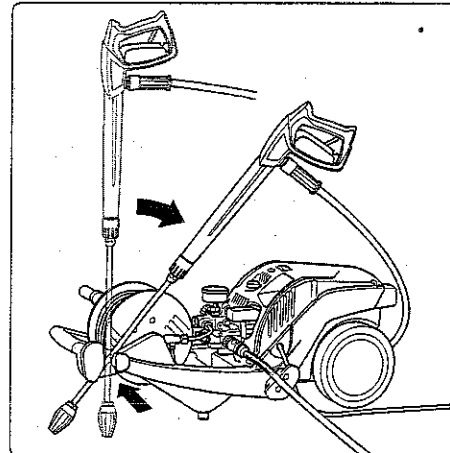

Kränzle 1122 TS T high-pressure cleaners are equipped with a practical holding device for trigger gun with Dirtkiller lance during breaks.

18 Suction of detergents

■ When using cleansing agents

Suction of cleansing agents by means of the detergent injector is only possible if the Vario Jet lance is fitted. The lance must be set to low pressure.

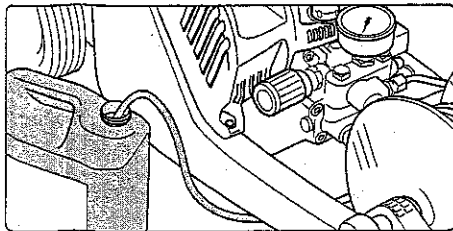

1. Please chemicals filter into container with cleansing agent.

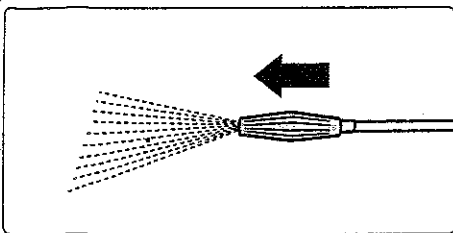

2. To reach the low pressure push Vario nozzle to the front so that the injector can suck in the cleansing agent.

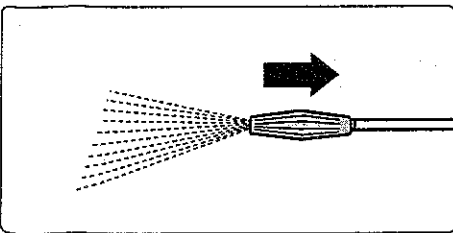

3. The chemicals supply is automatically stopped when closing the Vario nozzle by pushing it backwards. Let cleansing agent take effect and then spray off with a high-pressure jet.



Observe specifications of detergent manufacturer! e.g. protective equipment, rules for waste water treatment etc.



Caution: Solvents!
Never suck in liquids containing solvents like varnish solvents, petrol, oil or similar liquid! Observe specifications of detergent manufacturers! Seals inside the appliance are not resistant against solvents! The spray mist of solvents is highly inflammable, explosive and poisonous.

To shut down the pump

1. Switch off the high-pressure cleaner
2. Cut off the water supply
3. Open the trigger gun with safety catch briefly until the pressure is released
4. Apply safety catch on the trigger gun
5. Remove water hose and trigger gun with safety catch
6. Drain the pump: switch on the motor for approx. 20 seconds
7. Pull the plug from the socket
8. Clean HP hose and wind up without loops
9. Clean power cable and wind up
10. Clean water filter
11. Store high-pressure cleaners in frost-free rooms in winter

■ Store in a place-saving manner

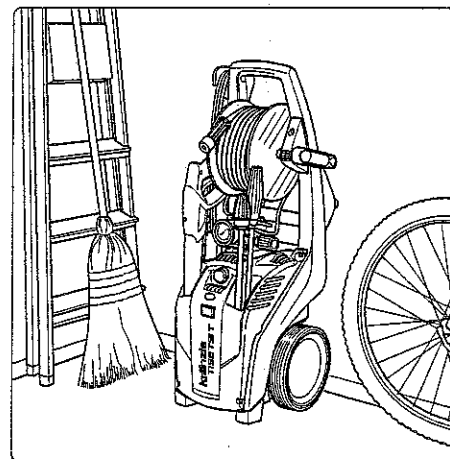

Due to their compact and space saving design the Kränzle 1152 TS T cleaners can be stored practically anywhere.

20 Small repairs - do it yourself!

■ No water from the nozzle but the gauge shows full pressure:
Most likely the nozzle is blocked.

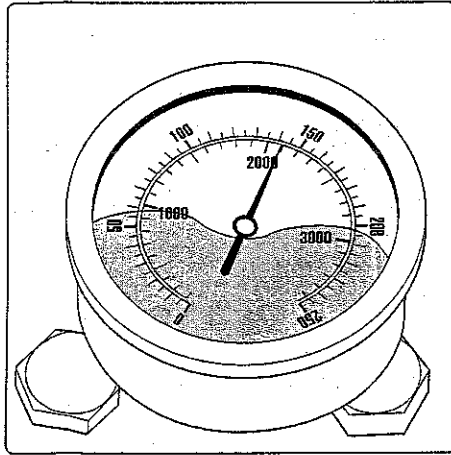

The pressure gauge shows full pressure, but emerges from the nozzle only little water or no water at all.

(Inside the pressure gauge there is no water but a filling with glycol to damp the vibration of the pointer.)

Proceeding:
Switch off the cleaner. Pull plug from the socket. Operate trigger gun with safety catch several times to decrease the pressure.

Unscrew trigger gun and lance first, then rinse high-pressure gun to remove possible soiling.

Check water inlet filter for soiling.

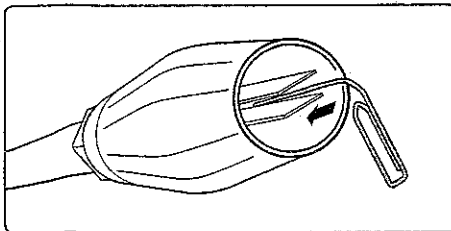

If the problem still exists, take wire (paper clip) and push through nozzle opening. If this procedure is not successful, the nozzle has to be dismantled and cleaned or even replaced, if necessary.



CAUTION! Pull plug from socket prior to starting any repair work!

■ Pressure gauge shows little pressure, the water from the nozzle comes in squirts: Most likely the valves are soiled or sticky.

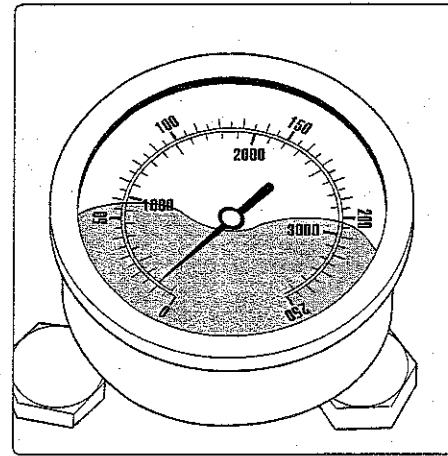

The pressure gauge shows little pressure despite fully turned up pressure regulation. The water from the lance comes in squirts. The HP hose vibrates.

(Inside the pressure gauge is no water but a filling with glycol to damp the vibration of the pointer.)

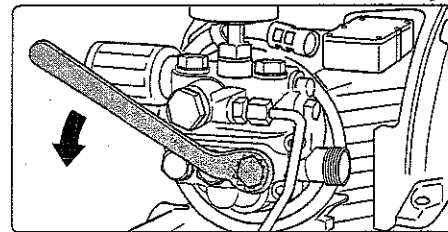

Proceeding:
Unscrew all 6 valves, one after the other (hexagonal brass screws, 3 in a row, vertically and horizontally)

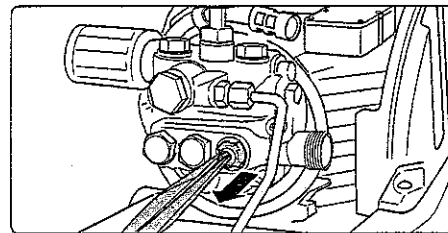

Take out valve body (with green or red plastic coating) and O-ring by means of needle nose pliers. Check O-ring for damage. In case of a damage the O-ring has to be replaced.

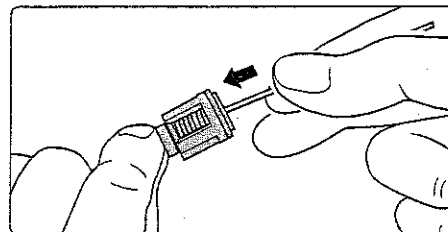

Take a wire (paper clip) and clean valves under running water.

Do not forget the O-ring during reassembly!

Small repairs - do it yourself!

■ The pressure gauge shows full pressure although the trigger gun with safety catch has been closed. The pressure switch valve switches constantly.

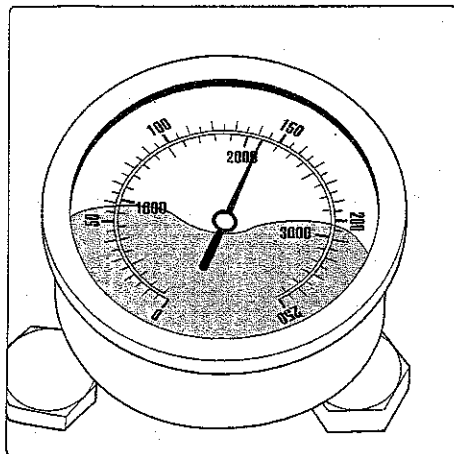

Possible cause no.1: Leakage

Having closed th trigger gun with safety catch, the HP cleaner must shut down and the pressure gauge must show „0“ bar.

If the pressure gauge shows full pressure but the motor constantly switches on and off, a leakage at the pump, at the high-pressure hose, at the trigger gun or at the lance can be the reason.

Proceeding:

Check connections from the HP cleaner to the high-pressure hose and from the hose to the trigger gun and also the connection between lance and trigger gun for tightness.

Switch off the cleaner. Shortly press the trigger of the trigger gun with safety catch to decrease the pressure.

Unscrew HP hose, trigger gun with safety catch and lance and check the O-rings.

If the O-rings are damaged they have to be replaced.

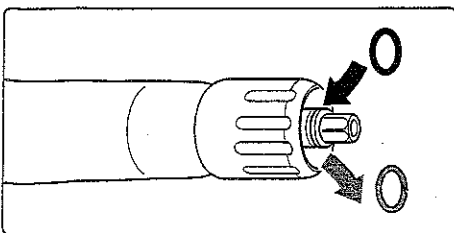
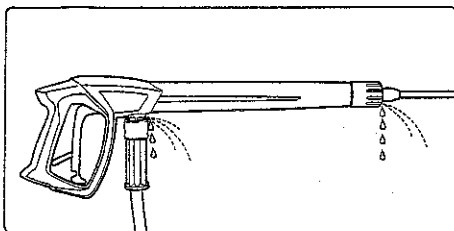

In case of a leakage there is no guarantee for possible consequential damages.

■ The pressure gauge shows full pressure although the trigger gun with safety catch has been closed. The motor constantly switches on and off.

Possible cause no. 2: The non-return valve is soiled or defective.

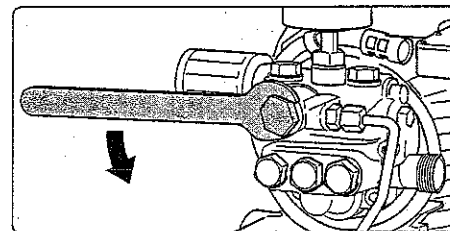

Proceeding:

Switch off the HP cleaner and pull plug from socket. Stop water supply. Unscrew pump outlet.

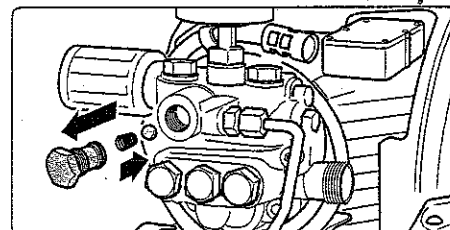

Take out check ball and check for soiling or damage.

Also check stainless steel seat of ball inside the pump housing for soiling or damage.

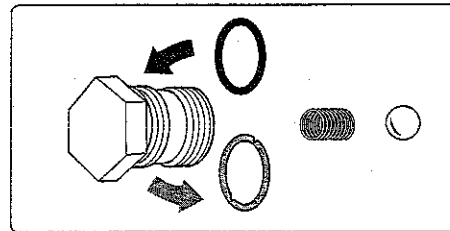

If sealing rings are defective replace O-rings at once.



There is no guarantee if the pump is damaged by defective O-rings due to air induction or lack of water (cavitation).

24 EC declaration of conformity

Hereby we declare that: Kränzle 1122 TST

technical specifications available from: **Manfred Bauer, Fa. Josef Kränzle**
Rudolf-Diesel-Str. 20, 89257 Illertissen

Nominal flow **K 1152 TST: 600 l/h**

comply with the following guidelines
 and their amendments for high-pressure
 cleaners: **Machinery directive 2006/42/EC**
EMC-directive 2004/108/EC
Noise directive 2005/88/EC, Art. 13
 HP water spraying machines
 Annex 3, part B, chapter 27

Sound level measured: **91 dB (A)**
 Sound level guaranteed: **93 dB (A)**

Applied conformity assessment
 procedure: **Annex V, Noise directive 2005/88/EC**

Applied specifications and standards:
EN 60 335-2-79 :2009
EN 55 014-1 :2006
EN 61 000-3-2 :2006
EN 61 000-3-3 :2008

I. Kränzle GmbH
 Elpke 97 D - 33605 Bielefeld

Bielefeld, Sept.03.09.2012

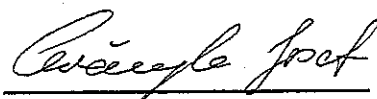

Kränzle Josef
 (Managing director)

Guarantee

The guarantee is only valid for material and manufacturing errors.
 Wearing does not fall within this guarantee.

The instructions in our operating manual must be complied with.
 The operating instructions form part of the guarantee.

For high-pressure cleaners sold to the user the guarantee period is **24 month**.
 For high-pressure cleaners sold for industrial use the guarantee period is **12 month**.

In the case of a guarantee please contact your dealer or authorized seller delivering
 accessories and your purchase receipt. You can find them in the internet under
www.kraenzle.com.

The guarantee is also void if the machine is used with exceeding the temperature and
 speed limits, a voltage below the required rating, with less than the required amount of
 water or with dirty water.

Pressure gauge, nozzle, valves, sleeves, high pressure hose and spray equipment are
 wear parts and are not covered by the guarantee.

26 Versatile due to Kränzle accessories

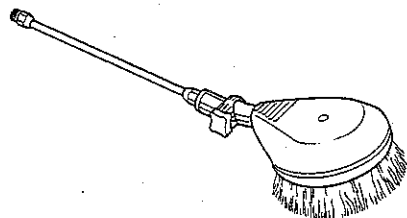

Rotating washing brush with 400 mm extension, Order no. 41.050 1

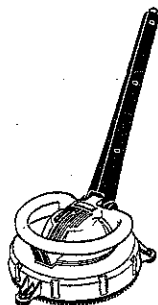
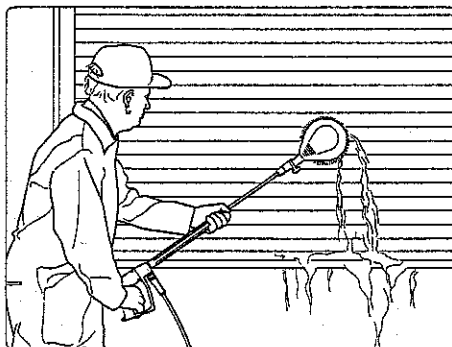

Floor cleaner round cleaner UFO
Order no. 41.850

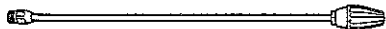

Dirtkiller lance with stainless steel pipe
400 mm, Order no. 41.072 5

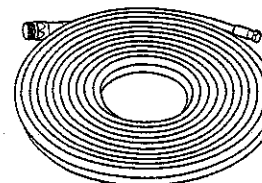
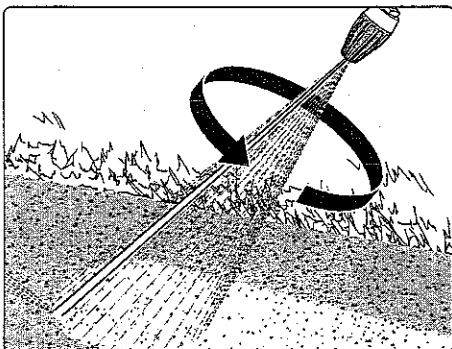

Pipe cleaning hose with nozzle,
10 m - order no. 41.058 1
15 m - order no. 41.058
20 m - order no. 41.058 2
25 m - order no. 41.058 3
30 m - order no. 41.058 4

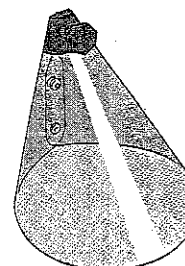
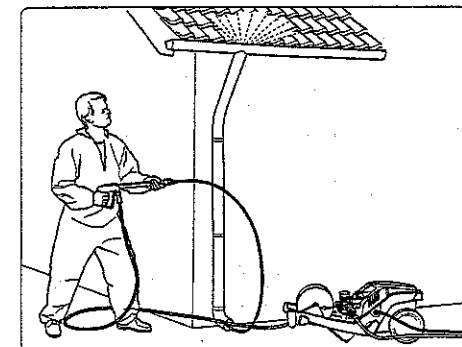

Spray guard
Order no. 41.052

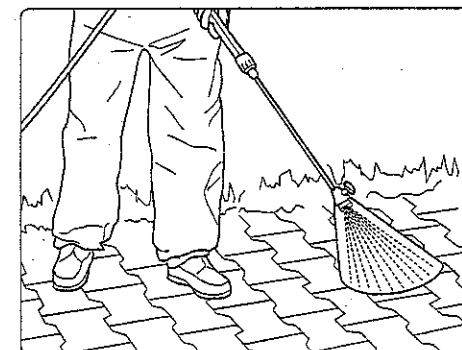

All accessories for high-pressure cleaners are safety components! These, in particular, include high-pressure hoses, trigger guns with safety catch, high-pressure lances, pipe cleaning hoses, surface cleaners, etc.
If components are used which are not approved by Kränzle any guarantee is rendered void.

28 Ersatzteilliste

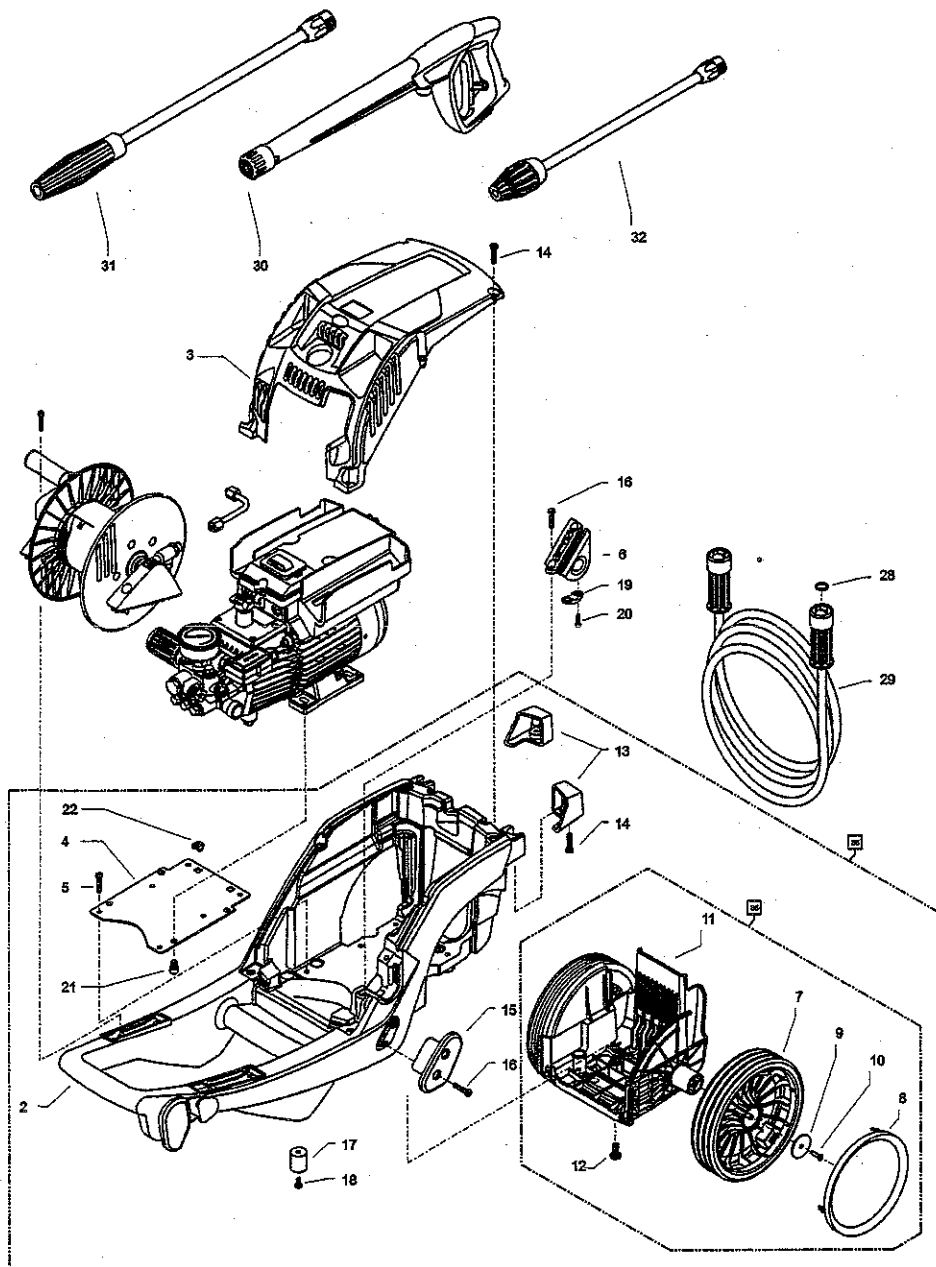

Kränzle 1122 TS T - Komplettaggregat

29

Position	Bezeichnung	Stck.	Art.-Nr.
2	Fahrgestell	1	49.000
3	Frontplatte „K 1122 TST“	1	49.007 2
4	Versteifungsplatte	1	49.008
5	Kunststoffschraube 6,0 x 30	6	43.423
6	Kabeltrompete	1	49.003
7	Rad	2	44.538
8	Radkappe	2	45.200 8
9	Scheibe 40 x 6 x 1,5 (Stahl)	2	45.216 7
10	Kunststoffsenschraube 5,0 x 20	2	45.421 1
11	Achshalter	1	49.001
12	Schraube M 6 x 35	2	49.015
13	Standfuss links+rechts	1	48.005
14	Schraube 5,0 x 30	8	43.418
15	Kabelaufwicklung K1152	1	49.002
16	Schraube 5,0 x 20	2	43.018
17	Gummi-Anschlag-Dämpfer 25 x 30	2	49.010
18	Schraube 5,0 x 14	2	43.426
19	Kabelklemme	1	43.431
20	Schraube 3,5 x 16	2	44.161
21	Schraube M 8 x 12	4	40.122
22	Käfigmutter M6	2	48.011
28	O-Ring 9,3 x 2,4	2	13.273
29	HD-Schlauch NW 6 15 m (K1152 TST)	1	48.015
30	Pistole M2000	1	12.480
31	Vario-Jet 03 kpl. mit Lanze	1	41.156 2
32	Schmutzkiller 03	1	41.073 8
35	Achse kpl. mit Räder	1	49.050
36	Fahrgestell kpl.	1	49.051

30 Ersatzteilliste

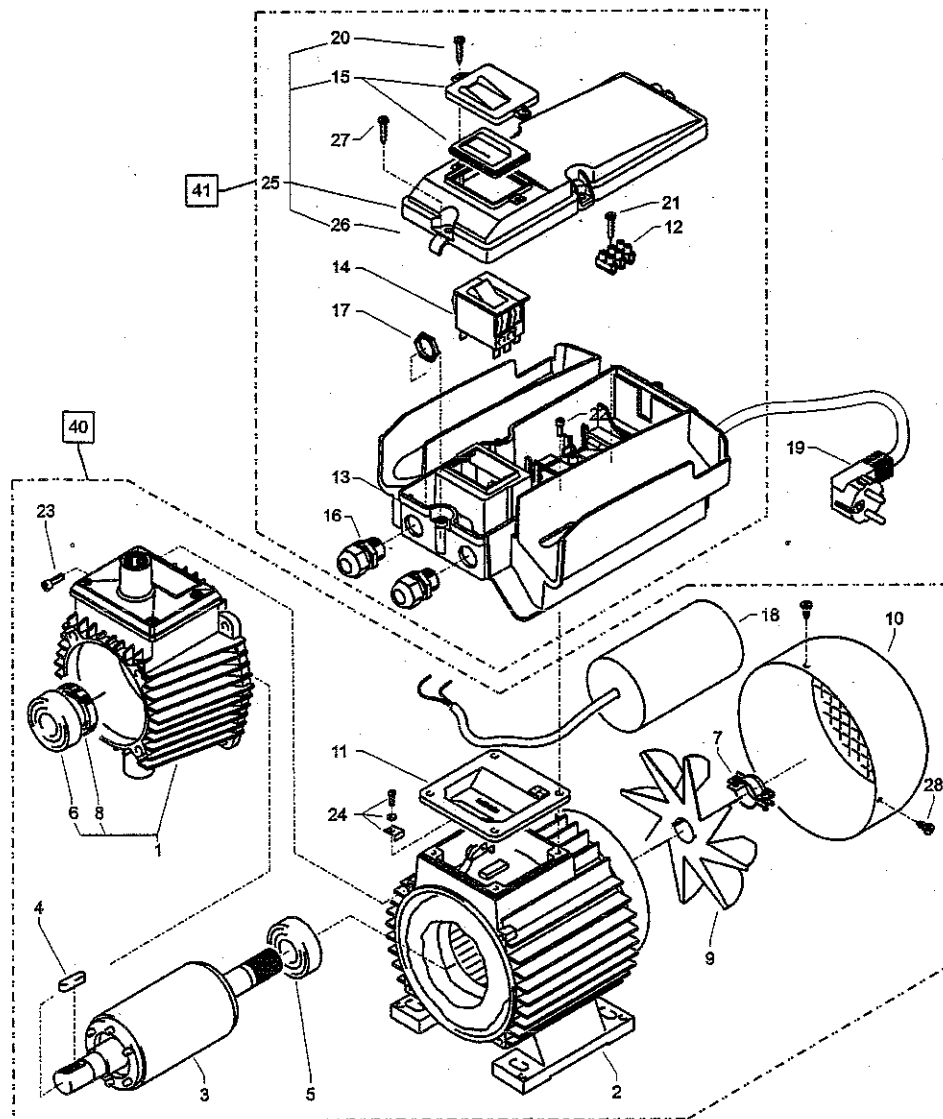

Kränzle 1122 TS T - Motor

Position	Bezeichnung	Stck.	Art.-Nr.
1	Ölgehäuse mit Dichtung, Deckel Öldichtung, Schulterlager	1	44.501
2	Motorgehäuse mit Stator K 1122 TTS 220-230V / 60 Hz	1	23.001 1
3	Motorwelle mit Rotor	1	43.104
4	Passfeder 6 x 6 x 20	1	41.483 1
5	Motor-Lager B-Seite Z-Lager	1	43.025
6	Motor-Lager A-Seite Schulterl.	1	43.026
7	Schelle für Lüfterrad	1	44.534 1
8	Öldichtung 25 x 35 x 7	1	41.024
9	Lüfterrad	1	44.534
10	Lüfterhaube	1	41.497
11	Flachdichtung	1	44.513
12	Lüsterklemme 3-pol.	1	43.031 2
13	Schaltkasten	1	49.004
14	Schalter mit 12 A-Überstromauslöser	1	43.033
15	Klemmrahmen mit Schalterabdichtung	1	43.453
16	Kabelverschraubung PG 13,5	2	40.536
17	Gegenmutter PG 13,5	2	44.253
18	Kondensator 40 µF	1	43.035
19	Netzkabel für 230V / 50/60Hz	1	41.092
20	Blechschaube 3,5 x 9,5	2	41.088
21	Blechschaube 2,9 x 16	1	43.036
22	Innensechskantschr. M 5 x 12	4	40.134
23	Innensechskantschr. M 5 x 30	4	42.130
24	Erdungsschraube kpl.	1	43.038
25	Deckel für Schaltkasten	1	49.005
26	Dichtung für Deckel	1	49.012
27	Kunststoffschraube 5,0 x 20	4	43.018
28	Blechschaube 3,9 x 13	3	41.078

32 Ersatzteilliste

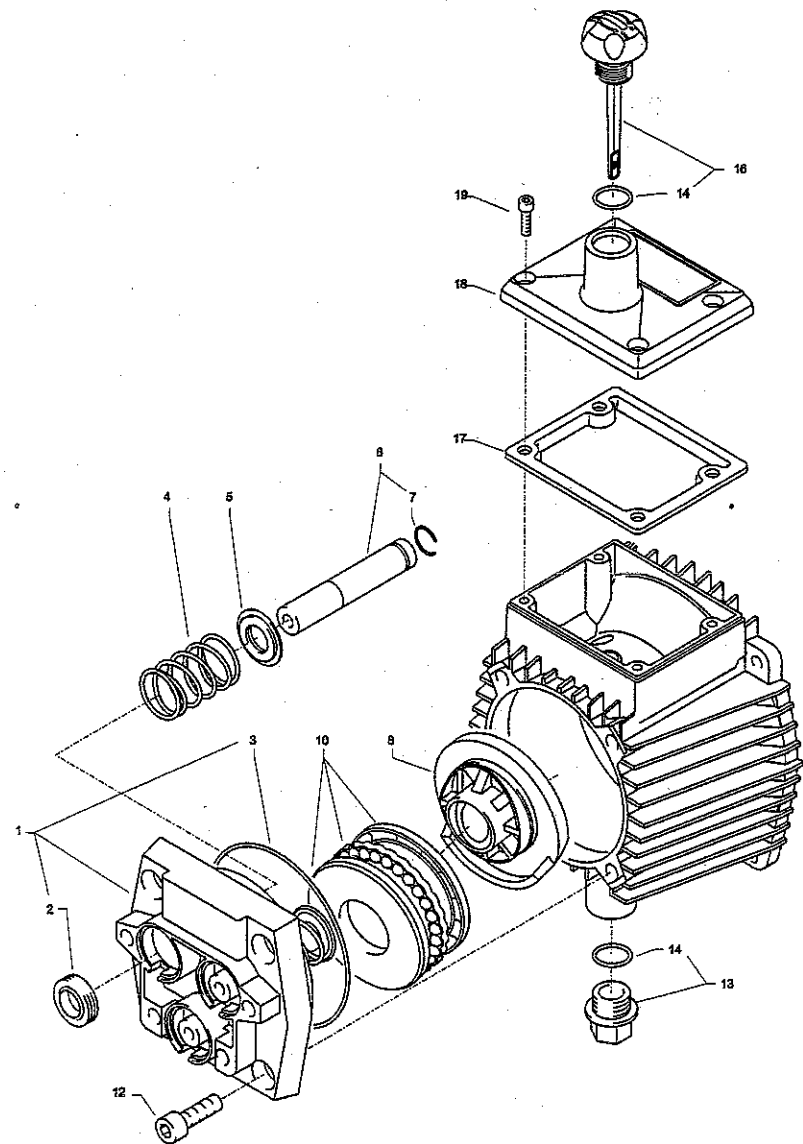

Kränzle 1122 TS T - Getriebeteil

Position	Bezeichnung	Stck.	Art.-Nr.
1	Gehäuseplatte	1	43.003
2	Öldichtung 14 x 24 x 7	3	41.631
3	O-Ring 83 x 2	1	43.039
4	Plungerfeder	3	43.040
5	Federdruckscheibe 14 mm	3	43.041
6	Plunger 14 mm AZ-L	3	49.021
7	Sprengring 14 mm	3	41.635
8	Taumelscheibe 10.75°	1	41.028-10,75
10	Axial-Rillenkugellager 3-teilig	1	43.486
12	Innensechskantschraube M 8 x 25	4	40.053
13	Ölablassstopfen M18x1,5 mit Magnet	1	48.020
14	O-Ring 14 x 2	1	43.445
16	Ölmessstab	1	49.009
17	Dichtung Öldeckel	1	44.501 1
18	Deckel Ölgehäuse	1	44.501 2
19	Innensechskantschraube M 5 x 12	4	41.019 4

34 Ersatzteilliste

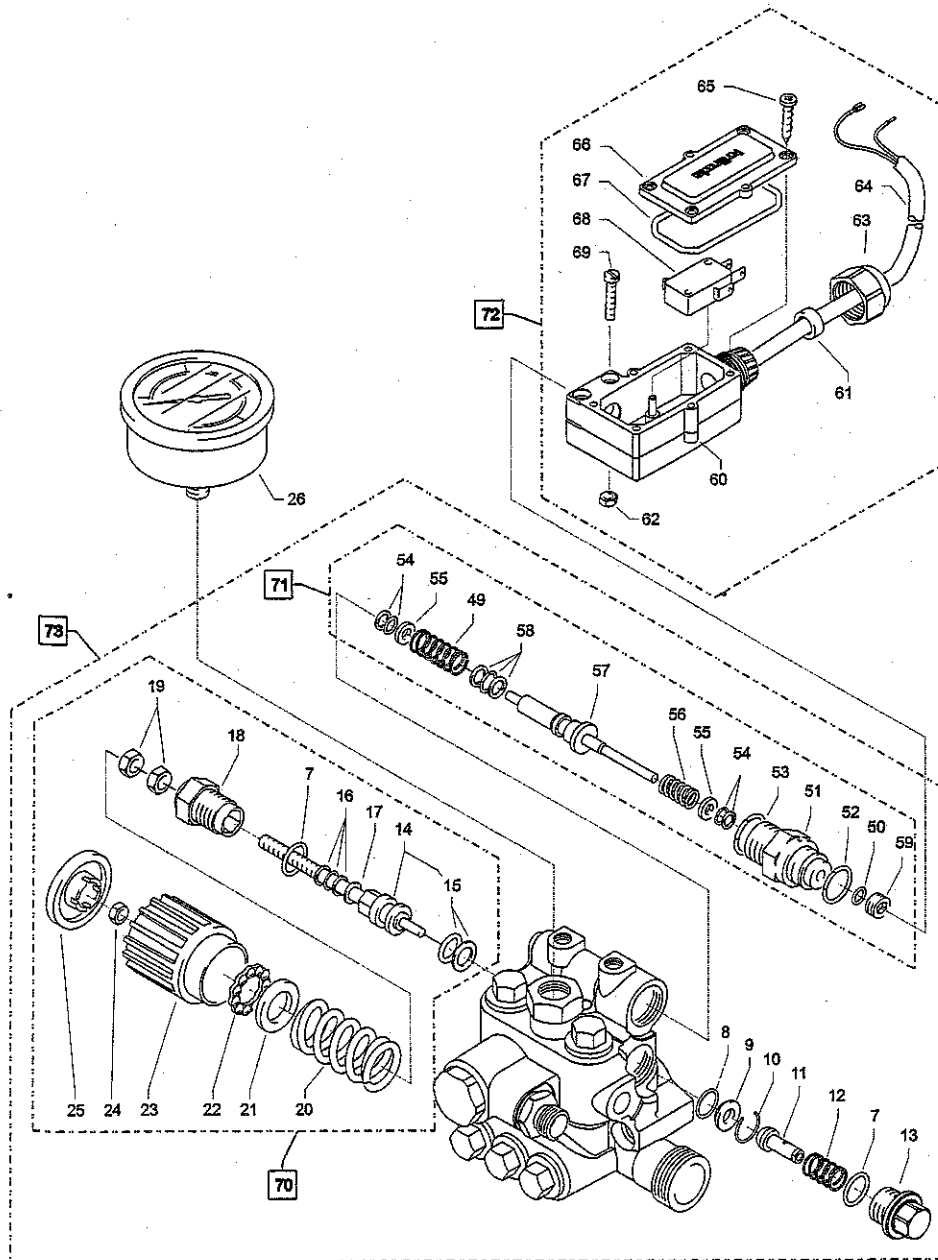

Kränzle 1122 TS T - Unloader + Druckschalter

Position	Bezeichnung	Stck.	Art.-Nr.
7	O-Ring 12 x 2	2	15.005 1
8	O-Ring 11 x 1,5	1	12.256
9	Edelstahlsitz	1	14.118
10	Sicherungsring	1	12.258
11	Anlaufentlastungsventil	1	49.040
12	Edelstahlfeder	1	14.119
13	Verschlusschraube	1	14.113
14	Steuerkolben 6 mm für AZ mit Dichtungen	1	44.532
15	Parbaks für Kolben 14 mm	1	14.123 1
16	Parbaks für Spindel 6 mm	1	14.123 2
17	MS-Scheibe	1	43.045
18	Kolbenführung 6 mm	1	14.130 1
19	Mutter M 6	2	14.127 1
20	Feder schwarz für AZ-Pumpe	1	43.046
21	Federdruckscheibe	1	43.047
22	Kugellager	1	43.048
23	Handrad M 6 für AZ-Pumpe	1	43.049
24	Mutter M 6 mit SW 8	1	43.010
25	Kappe für Handrad AZ-Pumpe	1	43.050
26	Manometer	1	15.039
49	Druckfeder 1 x 8,6 x 30	1	40.520
50	O-Ring 3,3 x 2,4	1	12.136
51	Führungsteil Steuerstößel	1	15.009 1
52	O-Ring 13 x 2,6	1	15.017
53	O-Ring 14 x 2	1	43.445
54	Parbaks 4 mm	2	12.136 2
55	Stützscheibe	2	15.015 1
56	Edelstahlfeder	1	15.016
57	Steuerstößel lang	1	15.010 2
58	Parbaks 7 mm	1	15.013
59	Stopfen M10x1 (durchgebohrt)	1	13.385 1
60	Gehäuse Elektroschalter	1	15.204
61	Gummimanschette	1	15.202
62	Sechskant-Mutter M 4	2	12.138
63	Überwurfmutter PG 11	1	15.203
64	Kabel 2 x 1,5 mm ²	1	49.023
65	Blechschaube 2,8 x 16	6	15.024
66	Deckel Elektroschalter	1	15.201
67	O-Ring 44 x 2,5	1	15.023
68	Mikroschalter	1	15.018
69	Zylinderschraube M 4 x 22	2	15.025
70	Steuerkolben kpl. m. Handrad		44.532 1
71	Rep.-Satz Druckschaltermechanik		15.009 3
72	Druckschalter kpl. ohne Mechanik		49.054
73	Ventilgehäuse kpl. für K1152 TST		49.052

36 Ersatzteilliste

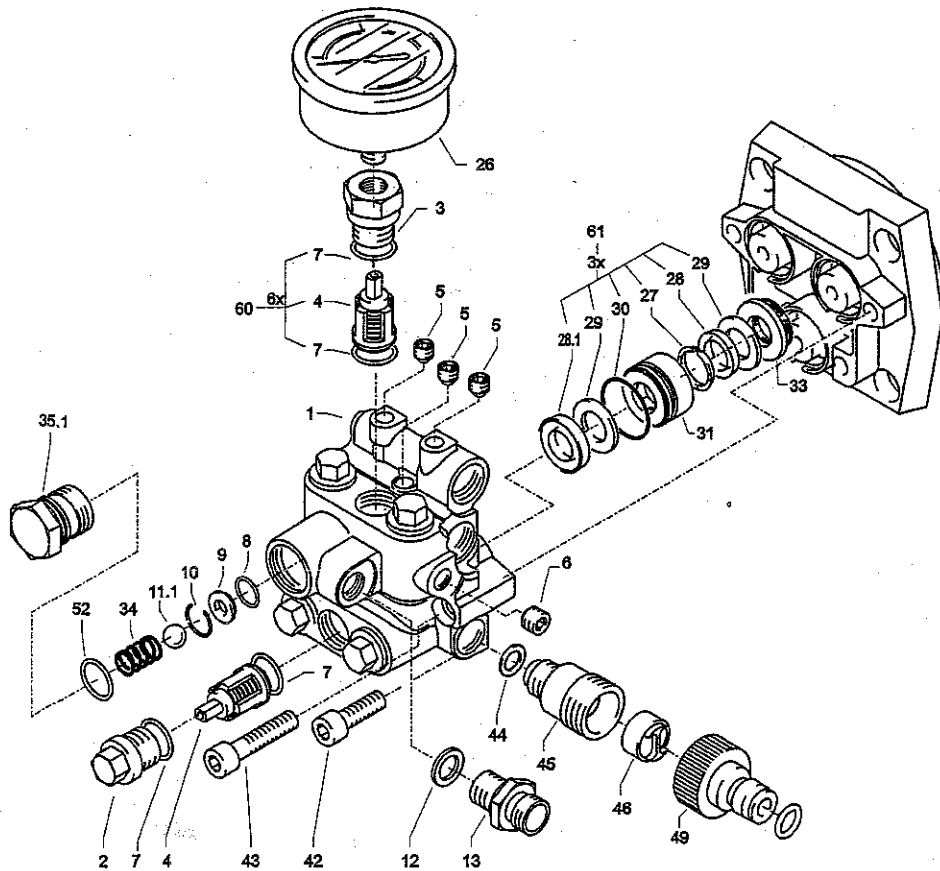

Kränzle 1122 TS T - Ventilgehäuse

Position	Bezeichnung	Stck.	Art.-Nr.
1	Ventilgehäuse	1	49.020
2	Ventilstopfen	5	41.011
3	Ventilstopfen mit R1/4" IG	1	41.011 1
4	Ventile (rot)	6	41.612
5	Dichtstopfen M 8 x 1	3	13.158
6	Dichtstopfen M 10 x 1	1	43.043
7	O-Ring 12 x 2	12	15.005 1
8	O-Ring 11 x 1,5	1	12.256
9	Edelstahlsitz	1	14.118
10	Sicherungsring	1	12.258
11.1	Edelstahlkugel 10,0 mm	1	12.122
12	Aluminium - Dichtring	3	13.275
13	Verschraubung Ermeto R1/4" x 8	1	41.042
26	Manometer	1	15.039
27	Stützring	3	41.618
28	Manschette 14 x 24 x 5/2,5	3	41.613
28.1	Gewebe-Manschette 14 x 24 x 5/2,5	3	41.613 1
29	Backring 14 x 24	6	41.614
30	O-Ring 24 x 2	3	49.024
31	Leckagering	3	49.022
33	Zwischenring mit Abstützung	3	43.055
34	Rückschlagfeder	1	14.120 1
35.1	Ausgangsteil (TST)	1	40.522
42	Innensechskantschr. M 8 x 25 - A2	2	40.053
43	Innensechskantschr. M 8 x 45 - A2	2	41.017
44	Dichtring Kupfer	1	14.149
45	Sauganschluss	1	41.016
46	Wasserfilter	1	41.046 2
49	Steckkupplung	1	41.047 2
52	O-Ring 18 x 2	1	43.446
60	Reparatur-Satz Ventile		41.648
61	Reparatur-Satz Manschetten		49.053

38 Ersatzteilliste

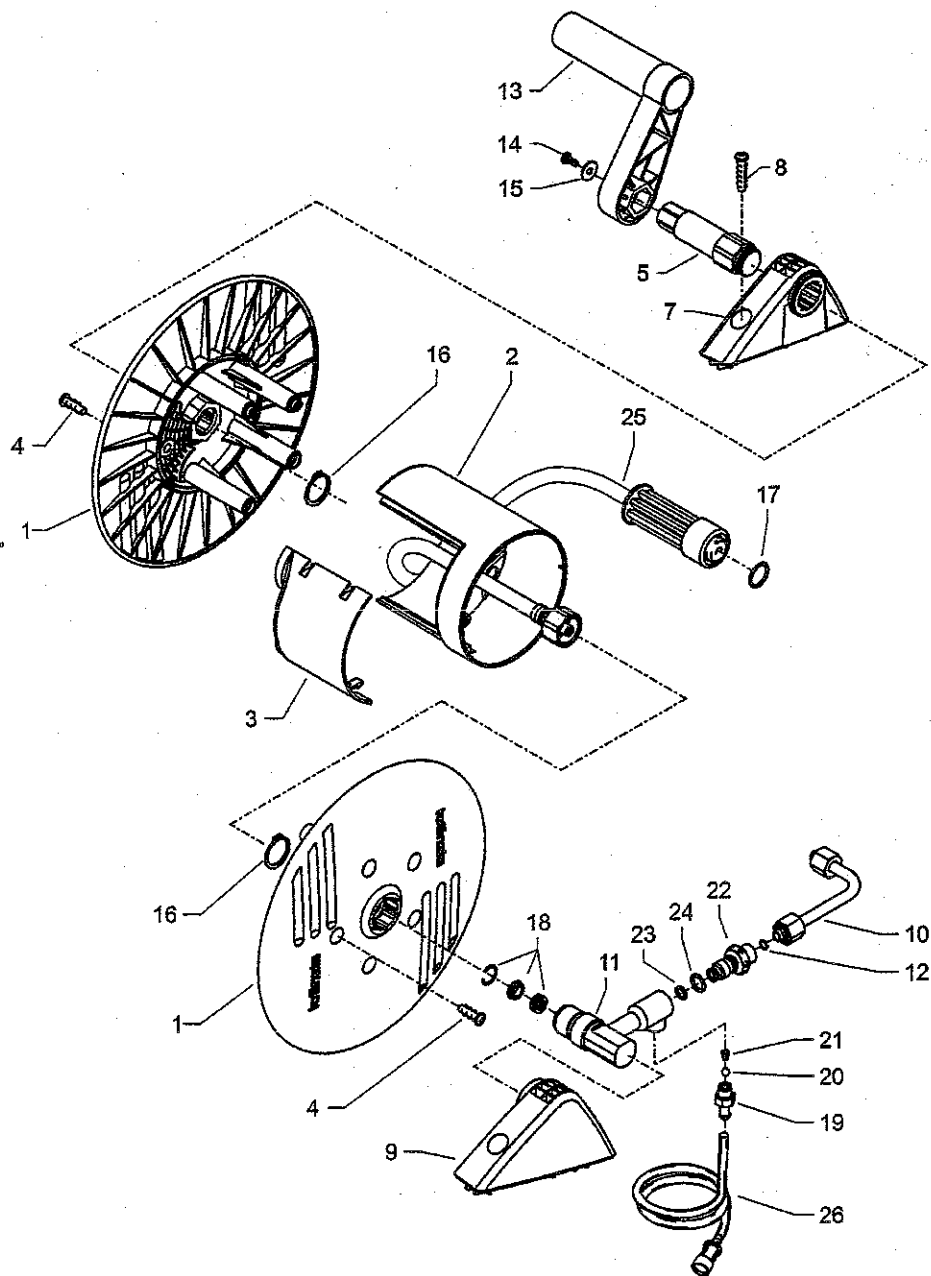

Kränzle 1122 TS T - Schlauchtrommel

Position	Bezeichnung	Stck.	Art.-Nr.
1	Seitenschale	2	48.101
2	Trommelteil	1	48.102
3	Knickschutz	1	40.162
4	Kunststoffschraube 5,0 x 20	5	43.018
5	Antriebswelle	1	48.104
7	Lagerklotz links	1	43.810
8	Schraube 6,0 x 30	4	43.423
9	Lagerklotz rechts	1	43.811
10	Verbindungsrohr	1	49.014
11	Wasser-Eingangsteil	1	48.103
12	O-Ring 6 x 0,8	2	40.177
13	Handkurbel	1	48.108
14	Schraube M 5 x 14	1	40.536
15	Scheibe 5,3	1	50.152
16	Wellensicherungsring 22 mm	2	40.117
17	O-Ring 9,3 x 2,4	1	13.273
18	Dichtsatz	1	13.410 1
19	Saugzapfen Schlauchanschluss	1	13.236
20	Edelstahlkugel 5,5 mm	1	13.238
21	Edelstahlfeder	1	13.239
22	Eingangsinjektor	1	40.317
23	O-Ring 10 x 2	1	43.068
24	O-Ring 6,68 x 1,78	1	40.585
25	Hochdruckschlauch 15m NW6	1	48.015
26	Chemikaliensaugschlauch mit Filter	1	15.038
30	Schlauchtrommel kpl., ohne HD-Schlauch		48.100

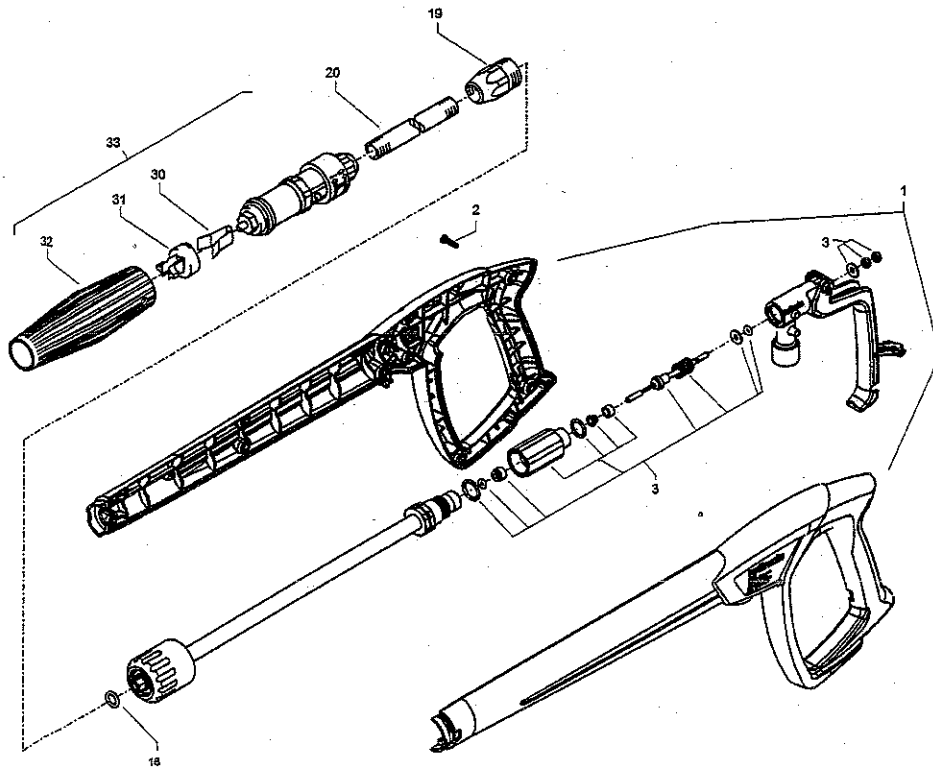

Kränzle 1122 TS T - Pistole und Lanze

Position	Bezeichnung	Stck.	Art.-Nr.
1	Pistolenschale rechts + links	1	12.450
2	Schraube 3,5 x 14	10	44.525
18	O-Ring 9,3 x 2,4	1	13.273
19	ST 30-Nippel M 22 x 1,5 AG / M 12 x 1	1	13.363
20	Rohr 400 lang, bds. M12 x 1	1	15.002
30	Klemmstück	1	41.155 2
31	Halterung für Klemmstück	1	41.155 4
32	Kunststoffhülle	1	41.155 1
33	Vario-Jet 03	1	41.155 9
M2000-Pistole kpl.			12.480
Lanze kpl. mit Vario-Jet 03			41.156 2

42 Ersatzteilliste Kränzle 1122 TS T
Schmutzkiller (Sonderzubehör)

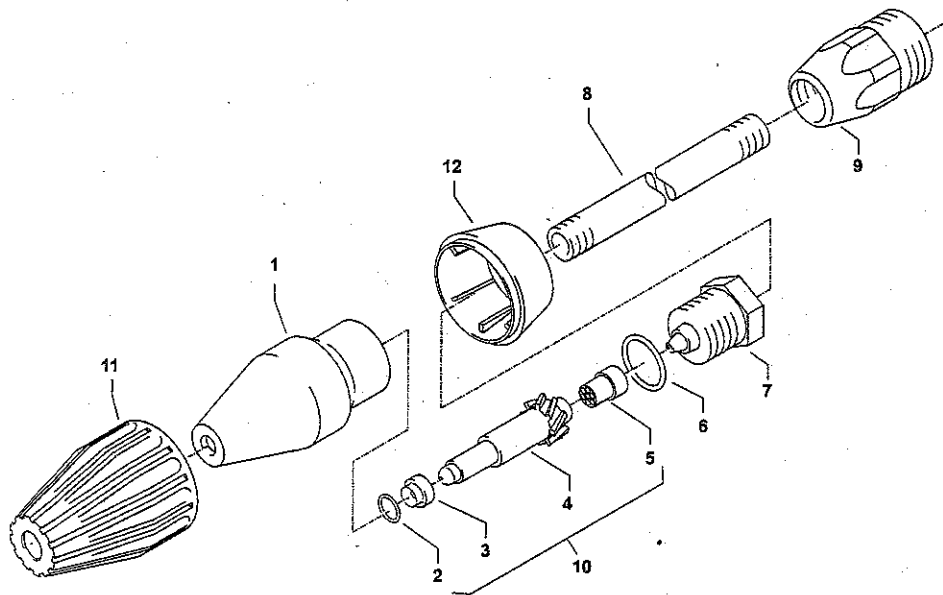

Position	Bezeichnung	Stck.	Art.-Nr.
1	Sprühkörper	1	41.520
2	O-Ring 6,88 x 1,68	1	41.521
3	Düsensitz	1	41.522
4	Düse 03	1	41.523 4
5	Stabilisator	1	41.524
6	O-Ring	1	40.016 1
7	Sprühstopfen	1	41.526
8	Rohr 400 mm 2x M 12 x 1	1	41.527
9	ST 30-Nippel M 22 x 1,5 / M 12 x 1 ISK	1	13.363
11	Kappe vorn für Schmutzkiller	1	41.528 1
12	Kappe hinten für Schmutzkiller 03	1	41.542 1
Rep.-Satz Schmutzkiller 03			41.096 1
bestehend aus je 1x 2; 3; 4; 5			
Schmutzkiller 03 kpl. mit Lanze			41.073 8

Schaltplan Kränzle 1122 TS T

